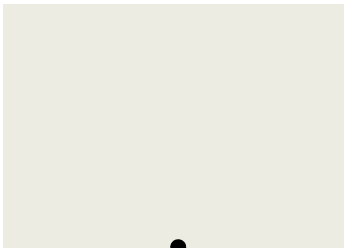

Exhibit A – Color Palette/Scheme



**Wall: Benjamin Moore
Vanilla Milkshake 2141-70**



**Roof, Trim, Accent, etc.: Sherwin-Williams
BRZ6 Medium Bronze**



Exhibit B – Proposed Wall Signs

Layout



Primary Wall Sign

Northeast Frontage - Forest Hill Blvd



18'

60'

Scale: 1/8" = 1'

Sign Area : 5' X 24' = 120 SQ FT
Frontage Area: 18'Hx60'W = 1080 SF



Flame to be backlit with a red light.
Rest of the sign to be backlit with a white light.

ANCHOR QUANTITY: 24' C/C TOP /BOTTOM	
WALL STRUCTURE	ANCHOR TYPE
STUCCO OVER 3/4" PLYWOOD	2.5" TAPCONS WITH WASHER HEAD
EFS OVER 5/8" PLYWOOD	LIBERTY TOGGLE BOLT
HOLLOW CONCRETE BLOCK, BRICK	SLEEVE ANCHOR (2" EMBEDMENT)
SOLID CONCRETE	WEDGE ANCHOR (3" EMBEDMENT)
CMU, SOLID CONCRETE, BRICK	MASONRY SCREW (3" EMBEDMENT)



Electrical Panel



EC13003378
954-923-3081
GM SIGNS
5991 SW 44TH STREET
DAVIE FLORIDA 33314
gmsigninc@aol.com

project name:

project address:

date:

scope of work:
Sign Plan Details & Specifications

client:

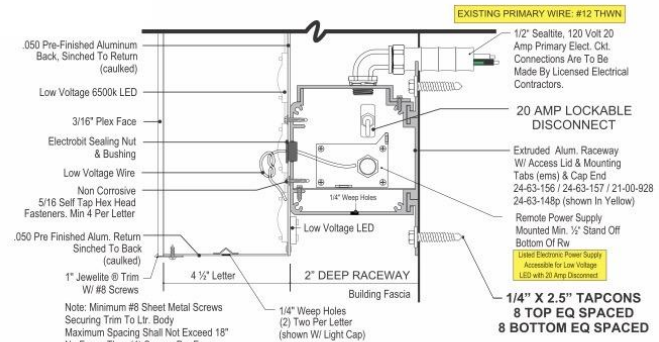

ELECTRICAL SPECIFICATIONS FOR CHANNEL LETTERS
2: 110 VOLT / LED SUPPLY @1.5 AMPS EACH
1: 20 AMP EXTERNAL DISCONNECT SWITCH
TOTAL LOAD: 3 AMP
Secondary Wire: Class 2 Cables per NEC 725.52
Primary Wire: per NEC 725.51
All Electrical Components UL Listed
Grounded Electric Power Supply Enclosure with Sheet Metal Cover, NEC 600-5, 600-8

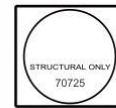

Note: Signs to withstand 170 MPH 47 PFS EXP C 3 Sec. Gusts as per ASCE 7-22 FBC 2023 8th Edition

Thomas R. Turberville, P.E.
1224 SW 32 Street
Fort Lauderdale, FL 33315

Secondary Wall Sign #1



Scale: 3/16" = 1'

Sign Area : 8.62"Hx94.9"W = 5.7 SF

Frontage Area: 18'Hx86.7'W = 1560.6 SF



1/2" THK. BLK ACRYLIC LETTERS

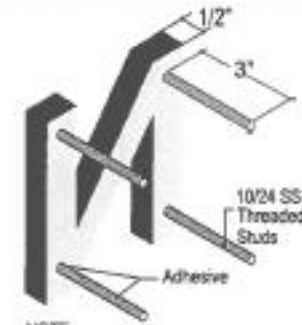

NOTE:

EMBEDMENT OF STUD IS 3" DEEP WITH CLEAR SILICONE INTO CBS WALL / HOLE DIA 3/16"

- Top / Bottom: 8.5" / 5.5" Letter Height
- Top / Bottom: 1/2" / Letter Thickness
- Top / Bottom: 3 / 4 Min. Studs per Letter
- Top / Bottom: BLK / Color
- CBS Wall Type

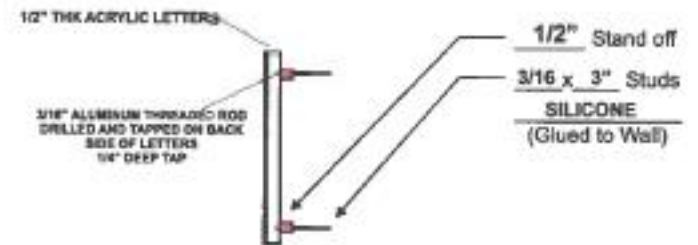

CBS
Wall Section

Note: Signs to withstand
180 MPH 47 PPS EXP C
3 Sec. Gusts as Per ASCE 7-22
FDC 2023 9th EDITION

Thomas R. Turberville, P.E.
1224 SW 32 Street
Fort Lauderdale, FL 33315



EC13003378
954-923-3081

Secondary Wall Sign #2

Southeast Frontage - State Hwy 88



Scale: 3/16" = 1'

Sign Area : 15"Hx171.73"W = 17.9 SF
 Frontage Area: 14'Hx33'W = 462 SF



1/2" THK. BLK ACRYLIC LETTERS

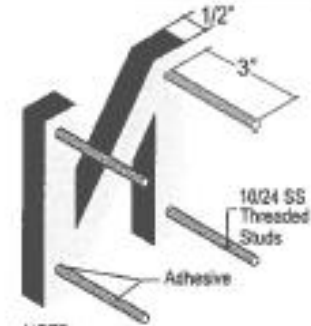

NOTE:
 EMBEDMENT OF STUD IS 3" DEEP
 WITH CLEAR SILICONE INTO
 CBS WALL / HOLE DIA 3/16"

Top / Bottom: 15" / 12" Letter Height
 Top / Bottom: 1/2" / Letter Thickness
 Top / Bottom: 3 / 4 Min. Studs per Letter
 Top / Bottom: BLK / Color
 CBS Wall Type

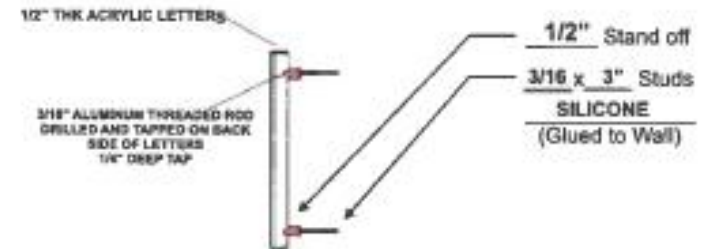

CBS
 Wall Section

Note: Signs to withstand
 100 MPH 47 PFS EDP C
 3 Sec. Gusts as PARASOL 7-02
 FSC 2023 8th EDITION

Thomas R. Turberville, P.E.
 1224 SW 32 Street
 Fort Lauderdale, FL 33315



Exhibit C – Applicant Justification Statement

RE: 12000 Forest Hill Blvd

Principal sign deviation and paint color approval

To Whom It May Concern:

I am requesting a deviation for the principal signage on my building located at 12000 Forest Hill Blvd. I am requesting that the principal sign be on the side of the building that faces Northeast and Forest Hill Blvd. The reason for this request is that this side of the building has ample wall space for a larger sign. Visibility for the public and passing traffic will be better on this side of the building. The current principal sign is very small and will only be visible from the parking lot and possibly from Ken Adams Way.

I am requesting an approval for the sign to be 60” high at its highest point, with letters that are 16”. The sign will be 125 square feet in size. We would like for the sign to be lit up with a white light with the exception of the flame being backlit with a red light.

I have permit applications submitted for a total of 3 signs to the building. I am including drawings for each sign and am requesting technical deviation for the principal sign.

In regards to the paint colors, when painting the building, we chose colors on the approved color pallet. The color for the building is Vanilla Milkshake and the roof and trim color are matched to be the same color as the approved roof color brown bronze. When visiting the office to see the approved color pallet, we were told by the young lady that showed us the colors that we did not need approval if we went with a color on the approved color pallet. We painted the building with the assumption that this was the case.

Thank you,

Sheldon Mickelson