

POD	LAND USE	ACREAGE	% OF SITE	FAR	BLDG. COVERAGE
A	COMMERCIAL	3.51	6.73%	.005	5.56%
B	COMMERCIAL	1.56	3%	.22	22.49%
C-1	RESIDENTIAL TOWNHOME / SINGLE-FAMILY	28.53	54.59% (2)	N/A	Note (1)
C-2	RESIDENTIAL / GENERAL OFFICE	1.21	2.3%	N/A	26.09%
D	CONSERVATION W/ PUBLIC REC	4.24	8.11%	N/A	N/A
E	OPEN SPACE (LAKE)	10.98	21%	N/A	N/A
E-1	PUBLIC REC	0.48	0.92%	N/A	N/A
E-2	PUBLIC REC	0.36	0.69%	N/A	N/A
E-3	PUBLIC REC	0.27	0.52%	N/A	N/A
E-4	PUBLIC REC	0.39	0.75%	N/A	N/A
E-5	PUBLIC GREENWAY	0.54	1.03%	N/A	N/A
E-6	PUBLIC REC	0.19	0.36%	N/A	N/A
TOTAL		52.26	100%		

SITE DATA	
PETITION NAME	LOTIS WELLINGTON 2
PETITION NUMBER	2022-0001-MP
LAND USE DESIGNATION	MIXED USE
ZONING DISTRICT	MUPD
OVERLAY(S) / NEIGHBORHOOD PLAN(S)	N/A
PROPERTY CONTROL NUMBER(S)	73-42-43-27-05-018-0072 73-42-43-27-05-018-0071 73-42-43-27-05-018-0040
COMMERCIAL FAR	0.01
RESIDENTIAL DENSITY	3.29 DU/AC
EXISTING USE(S)	VACANT
PROPOSED USE(S)	MIXED USE
GROSS SITE AREA	52.259 AC

NOTE:  
 1. REFER TO PROJECT STANDARDS MANUAL FOR INDIVIDUAL LOT REQUIREMENTS.  
 2. SECTION 6.5.4 MULTIPLE USE PLANNED DEVELOPMENT EACH LAND USE IS LIMITED TO 30% GROSS AREA. CONCURRENT TEXT AMENDMENT IN PROCESS TO ALLOW FOR A WAIVER TO BE GRANTED BY VILLAGE COUNCIL TO ALLOW UP TO 60% RESIDENTIAL USE.  
 3. GENERAL OFFICE USE WITHIN POD C-2 RESIDENTIAL WILL BE OPEN TO THE PUBLIC AND RESIDENTS OF LOTIS. GENERAL OFFICE WILL NOT BE CALCULATED PER REQUIRED AND PROVIDED PRIVATE RECREATION.

DEVELOPMENT TEAM	
<b>DEVELOPER</b>	LOTIS WELLINGTON 2, LLC. 2300 GLADES RD, SUITE 202E BOCA RATON, FL 33431 561.866.6884
<b>PLANNER &amp; LANDSCAPE ARCHITECT</b>	INSITE STUDIO, INC. 3601 PGA BLVD SUITE 220 PALM BEACH GARDENS, FL 33410 561.249.0940
<b>CIVIL ENGINEER</b>	SCHNARS ENGINEERING CORP. 947 CLINT MOORE ROAD BOCA RATON, FL 33487 561.241.6455
<b>TRAFFIC ENGINEER</b>	JFO GROUP, INC. 6671 W INDIANTOWN RD, SUITE 50-324 JUPITER, FL 33458 561.462.5364
<b>ENVIRONMENTAL</b>	ECOTONE SERVICES 13945 89TH STREET FELLSMERE, FL 32948 772.459.3339
<b>SURVEY</b>	DENNIS J LEAVY & ASSOCIATES 460 BUSINESS PARK WAY, SUITE B ROYAL PALM BEACH, FL 33411 561.753.0650

**insite studio**  
 planning + landscape architecture  
 3601 PGA Blvd Suite 220, Palm Beach Gardens, FL 33410  
 phone: 561-249-0940 | email: info@insitestudio.com  
 www.insitestudio.com | License#: LC26000606

Consultants:

Revisions:

05/16/2023	- Resubmittal
06/28/2023	- Resubmittal
08/02/2023	- Resubmittal
08/25/2023	- Resubmittal
09/21/2023	- Resubmittal

**Exhibit B**  
 Master Plan including Phasing,  
 Regulating Plan and  
 Circulation Plan  
 (Sheet 1 of 3)

RESIDENT CALCULATIONS			
UNIT TYPE	RESIDENT / UNIT	# OF DU	RESIDENTS
TOWNHOME	3.02 / DU	72	217
SINGLE FAMILY	3.02 / DU	100	302
TOTAL NUMBER OF RESIDENTS			519

CIVIC REQUIREMENTS			
UNIT TYPE	RESIDENT / UNIT	RESIDENTS	RESIDENTS
TOWNHOME	43.56 SF / CAPITA	217	0.22 AC
SINGLE FAMILY	43.56 SF / CAPITA	302	0.3 AC
TOTAL		519	0.52 AC
TOTAL PROVIDED			0 AC

PRIVATE RECREATION REQUIREMENTS			
UNIT TYPE	CALCULATION	RESIDENTS	AREA REQUIRED
TOWNHOME	110 SF / CAPITA	217	0.55 AC
SINGLE FAMILY	110 SF / CAPITA	302	0.76 AC
TOTAL		519	1.31 AC

PRIVATE RECREATION PROVIDED	
POD	AREA PROVIDED
POD C-1	0.37 AC
POD C-2	1.21 AC
TOTAL	1.58 AC

PUBLIC RECREATION REQUIREMENTS			
UNIT TYPE	CALCULATION	RESIDENTS	AREA REQUIRED
TOWNHOME	217.8 SF / CAPITA	217	1.09 AC
SINGLE FAMILY	217.8 SF / CAPITA	302	1.51 AC
TOTAL		519	2.6 AC

PUBLIC RECREATION PROVIDED			
POD	AREA PROVIDED	% CREDIT	TOTAL AC CREDIT
POD E-1 PUBLIC REC	0.48 AC	23%	0.1104 AC
POD E-2 PUBLIC REC	0.36 AC	23%	0.0828 AC
POD E-3 PUBLIC REC	0.27 AC	23%	0.0621 AC
POD E-4 PUBLIC REC	0.39 AC	23%	0.0897 AC
POD E-5 - PUBLIC GREENWAY	0.54 AC	23%	0.1242 AC
POD E-6 PUBLIC REC	0.19 AC	23%	0.0437 AC
POD D - CONSERVATION W/ PUBLIC REC	4.24 AC	23%	0.9752 AC
PRIVATE RECREATION [C-1 / C-2]	1.58 AC	23%	0.3634 AC
TOTAL	8.05 AC		1.8515 AC

PHASING		
POD	LAND USE	PHASE
A	COMMERCIAL	3
B	COMMERCIAL	2
C-1	RESIDENTIAL TOWNHOME / SINGLE-FAMILY	1B
C-2	RESIDENTIAL / GENERAL OFFICE	1A
D	CONSERVATION W/ PUBLIC REC	1A
E	OPEN SPACE (LAKE)	1A
E-1	PUBLIC REC	1C
E-2	PUBLIC REC	1C
E-3	PUBLIC REC	1C
E-4	PUBLIC REC	1C
E-5	PUBLIC GREENWAY	1C
E-6	PUBLIC REC	1C

DEVELOPMENT BREAKDOWN		
POD	USE	SF / DU / ACRES [AC]
A	INDOOR/OUTDOOR ENTERTAINMENT	8,000 SF INCLUDING RESTAURANT / RETAIL AND 36 MINIATURE GOLF HOLES
B	DAYCARE	18,000 SF (210 KIDS)
C-1	RESIDENTIAL (SINGLEFAMILY / TOWNHOME)	172 DU
C-2	RESIDENTIAL / GENERAL OFFICE	11,470 SF CLUBHOUSE 1,030 SF OFFICE
D	CYPRESS PRESERVE W/ PUBLIC REC	4.24 AC

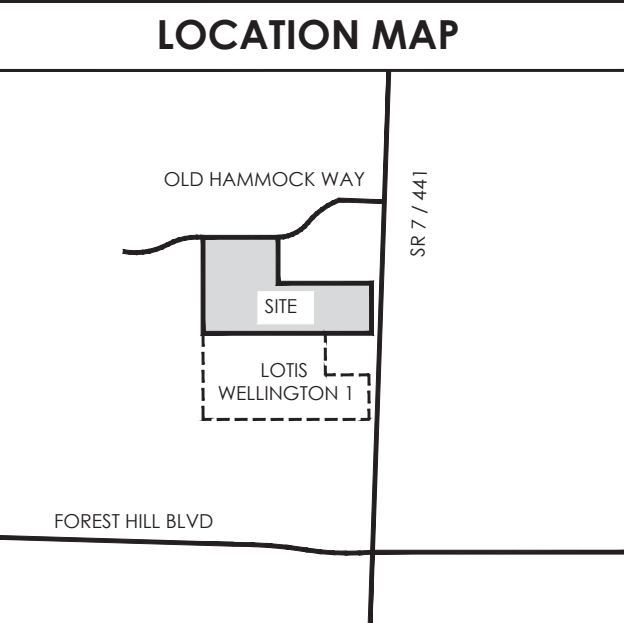

APPROVALS	

**LEGAL DESCRIPTION**

Parcel 1  
 Tract 4 of Block 18 of PALM BEACH FARMS CO. PLAT NO. 3, according to the plat thereof recorded in Plat Book 2, pages 45 to 54 of the public records of Palm Beach County, Florida.

Parcel 2  
 The North 330 feet of Tract 7, in Block 18, of THE PALM BEACH FARMS CO. PLAT NO. 3, according to the Plat thereof as recorded in Plat Book 2, page 45 of the public records of Palm Beach County, Florida, LESS AND EXCEPT the Westerly 15 feet and the right of way of State Road 199 as set forth in Deed Book 636, page 96 and in Road Plat Book 1, page 43, therefrom;

AND LESS AND EXCEPT the following:  
 A portion of Tract 7, in Block 18, of PALM BEACH FARMS CO. PLAT NO. 3, as recorded in Plat Book 2, page 45 of the public records of Palm Beach County, Florida, lying in Section 12, Township 44 South, Range 41 East, being more particularly described as follows:  
 Commence at the found Palm Beach County brass disc in concrete marking the West 1/4 corner of said Section 12; thence South 87° 48' 12" East along the East-West 1/4 Section line, a distance of 1,613.491 meters (5,293.61 feet) to the East 1/4 corner of said Section 12; thence North 88° 21' 42" West, a distance of 0.360 meters (1.18 feet) to the Baseline of Survey for State Road 7 (U.S. 441) as shown on that Florida Department of Transportation Right of Way Map for Section 93210-2519; thence North 01° 38' 18" East along said Baseline of Survey, a distance of 103.331 meters (339.01 feet); thence North 01° 38' 26" East continuing along said Baseline of Survey, a distance of 200.392 meters (657.45 feet); thence North 88° 21' 34" West along a line at right angles to the last described course, a distance of 73.153 meters (240.00 feet) to the POINT OF BEGINNING; thence North 01° 38' 26" East, a distance of 100.698 meters (330.37 feet); thence North 88° 56' 34" East, a distance of 50.349 meters (165.19 feet) to the westerly existing right of way line for said State Road 7 (U.S. 441); thence South 01° 38' 26" West along said westerly existing right of way line, a distance of 100.698 meters (330.37 feet); thence South 88° 56' 34" West, a distance of 50.349 meters (165.19 feet) to the POINT OF BEGINNING.

AND LESS AND EXCEPT the following:  
 A portion of Tract 7, in Block 18, of PALM BEACH FARMS CO. PLAT NO. 3, as recorded in Plat Book 2, Page 45, of the Public Records of Palm Beach County, Florida, lying in Section 12, Township 44 South, Range 41 East, being more particularly described as follows:

**LEGAL DESCRIPTION CONT.**

Parcel 3  
 Tract 7, excepting therefrom the North 330 feet thereof, and excepting therefrom state road right of way as set forth in Deed Book 636, page 96, Road Plat Book 1, page 43 and the Order of Taking recorded in Official Records Book 9504, page 1398; all of Tract 8 and Tract 9, excepting therefrom the West 15 feet thereof, in Block 18 of THE PALM BEACH FARMS CO. PLAT NO. 3, according to the plat thereof recorded in Plat Book 2, pages 45 to 54, both inclusive, all of the public records of Palm Beach County, Florida.

Parcel 4  
 The West 15 feet of the North 330 feet of Tract 7, Block 18 of THE PALM BEACH FARMS CO. PLAT NO. 3, according to the plat thereof recorded in Plat Book 2, pages 45 to 54, both inclusive, public records of Palm Beach County, Florida, together with the south half of the road lying northerly thereof as shown on said plat.

Parcel 5  
 That portion of the 25 foot road shown on the plat of the THE PALM BEACH FARMS CO. PLAT NO. 3, according to the plat thereof recorded in Plat Book 2, pages 45 to 54, both inclusive, public records of Palm Beach County, Florida, lying southerly of Tract 4 and northerly of Tract 9 in Block 18, less the West 15 feet thereof; and the south half of that portion of said road lying northerly of Tracts 7 and 8, Block 18 of said plat, less that part lying with in the right of way of State Road 7, and less that part lying northerly of the West 15 feet of Tract 7.

Said lands situate, lying and being in Palm Beach County, Florida.

**LOTIS WELLINGTON II**  
 Wellington, Florida

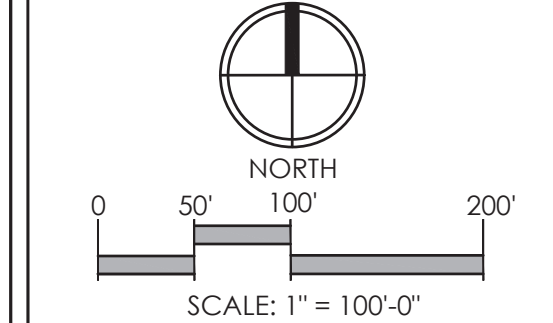

Drawn By: TAC  
 Drawing #: 1076  
 Date: 04/28/2022

**Master Plan**  
 SHEET # MP.1

Consultants:

Revisions:

08/02/2023 - Resubmittal

09/21/2023 - Resubmittal

**A TYPE A 10' LANDSCAPE BUFFER - 2, 7**

NOTES:  
-FIELD ADJUSTMENT OF BERMS, WALLS AND PLANT MATERIALS MAY BE PERMITTED TO PROVIDE PEDESTRIAN SIDEWALKS/BIKE PATHS AND TO ACCOMMODATE TRANSVERSE UTILITY OR DRAINAGE EASEMENT CROSSINGS AND EXISTING VEGETATION.  
-ALL CANOPY TREES TO BE PLANTED WITHIN OVERHEAD UTILITIES EASEMENTS SHALL BE CONSISTENT WITH FP&L'S TREE LIST SUGGESTED IN THE "PLANT THE RIGHT TREE IN THE RIGHT PLACE" GUIDELINES AND PURSUANT TO SECTION 7.3.E.12.A OF THE ULDC.  
-ALL PALMS SHALL HAVE A MINIMUM 12" WOOD TRUNK AND CLUSTERS SHALL INCLUDE STAGGERED HEIGHTS OF 12' - 18'.  
-ALL SPECIES, HEIGHT AND LOCATION SHALL REQUIRE VILLAGE OF WELLINGTON APPROVAL.  
-A GROUP OF 3 OR MORE PALMS (AS APPROVED BY VOW) MAY SUPERSEDE THE REQUIREMENT FOR A CANOPY TREE IN THAT LOCATION.

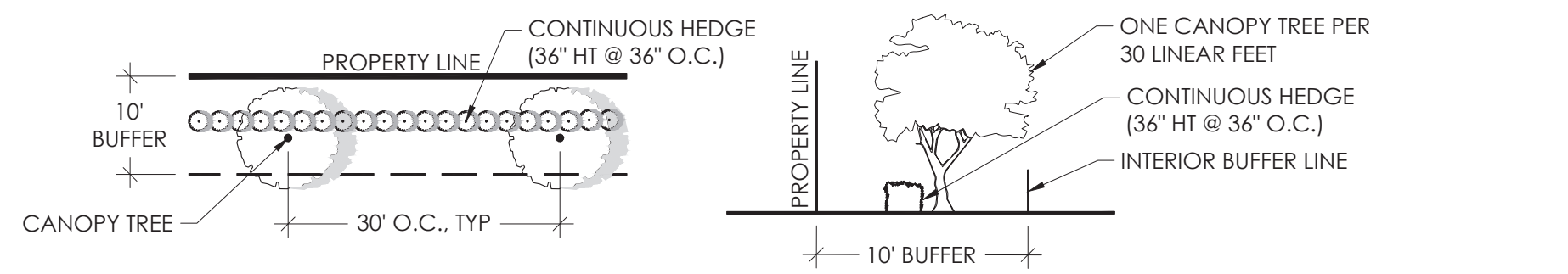

**B TYPE B ROW 25' LANDSCAPE BUFFER - 1**

NOTES:  
-FIELD ADJUSTMENT OF BERMS, WALLS AND PLANT MATERIALS MAY BE PERMITTED TO PROVIDE PEDESTRIAN SIDEWALKS/BIKE PATHS AND TO ACCOMMODATE TRANSVERSE UTILITY OR DRAINAGE EASEMENT CROSSINGS AND EXISTING VEGETATION.  
-ALL CANOPY TREES TO BE PLANTED WITHIN OVERHEAD UTILITIES EASEMENTS SHALL BE CONSISTENT WITH FP&L'S TREE LIST SUGGESTED IN THE "PLANT THE RIGHT TREE IN THE RIGHT PLACE" GUIDELINES AND PURSUANT TO SECTION 7.3.E.12.A OF THE ULDC.  
-ALL PALMS SHALL HAVE A MINIMUM 12" WOOD TRUNK AND CLUSTERS SHALL INCLUDE STAGGERED HEIGHTS OF 12' - 18'.  
-ALL SPECIES, HEIGHT AND LOCATION SHALL REQUIRE VILLAGE OF WELLINGTON APPROVAL.  
-A GROUP OF 3 OR MORE PALMS (AS APPROVED BY VOW) MAY SUPERSEDE THE REQUIREMENT FOR A CANOPY TREE IN THAT LOCATION.  
-LANDSCAPE BUFFER AND BERM REQUIREMENTS ADJACENT TO STATE ROAD 7 ARE PER LDR SEC.7.3.6.T.

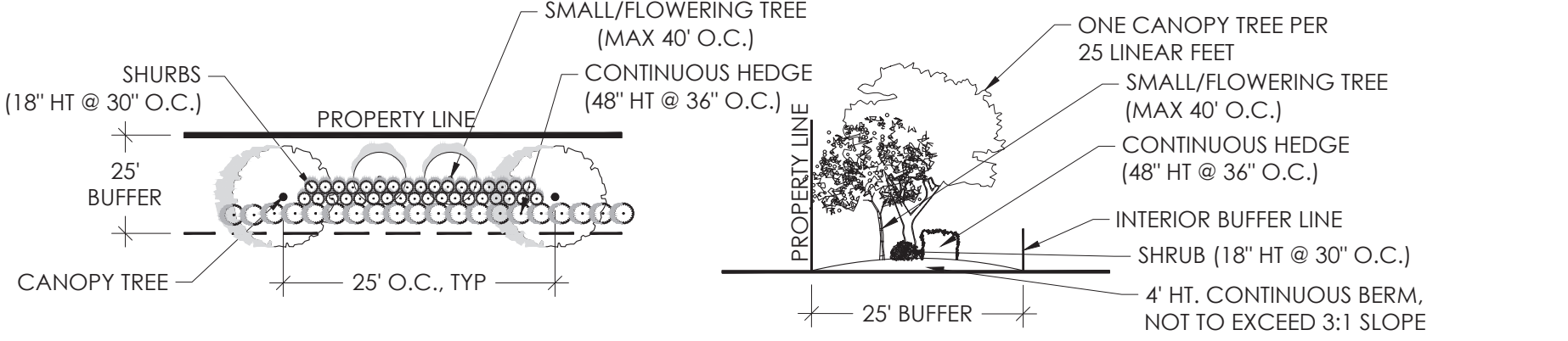

**C TYPE A/F 20'-22' LANDSCAPE BUFFER - 3, 4, 5, 6**

NOTES:  
-FIELD ADJUSTMENT OF BERMS, WALLS AND PLANT MATERIALS MAY BE PERMITTED TO PROVIDE PEDESTRIAN SIDEWALKS/BIKE PATHS AND TO ACCOMMODATE TRANSVERSE UTILITY OR DRAINAGE EASEMENT CROSSINGS AND EXISTING VEGETATION.  
-ALL CANOPY TREES TO BE PLANTED WITHIN OVERHEAD UTILITIES EASEMENTS SHALL BE CONSISTENT WITH FP&L'S TREE LIST SUGGESTED IN THE "PLANT THE RIGHT TREE IN THE RIGHT PLACE" GUIDELINES AND PURSUANT TO SECTION 7.3.E.12.A OF THE ULDC.  
-ALL PALMS SHALL HAVE A MINIMUM 12" WOOD TRUNK AND CLUSTERS SHALL INCLUDE STAGGERED HEIGHTS OF 12' - 18'.  
-ALL SPECIES, HEIGHT AND LOCATION SHALL REQUIRE VILLAGE OF WELLINGTON APPROVAL.  
-A GROUP OF 3 OR MORE PALMS (AS APPROVED BY VOW) MAY SUPERSEDE THE REQUIREMENT FOR A CANOPY TREE IN THAT LOCATION.

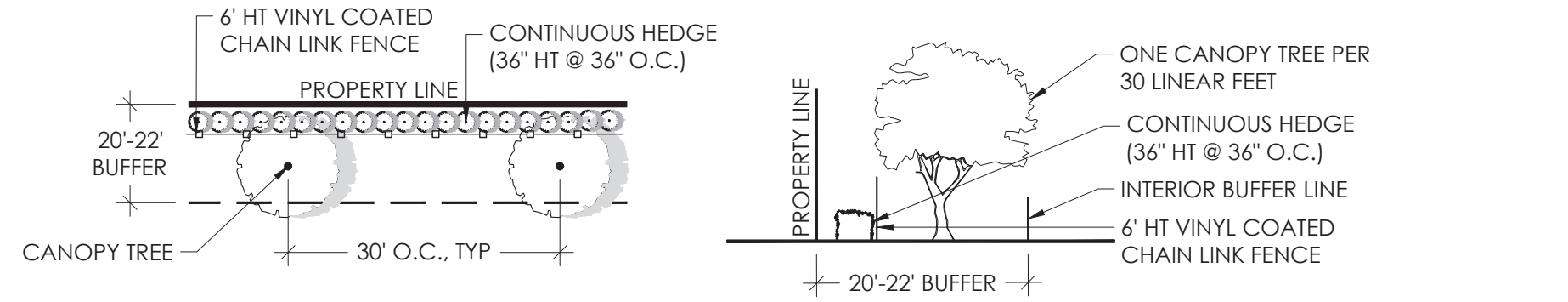

**D ENHANCED CROSSWALK SYSTEM**

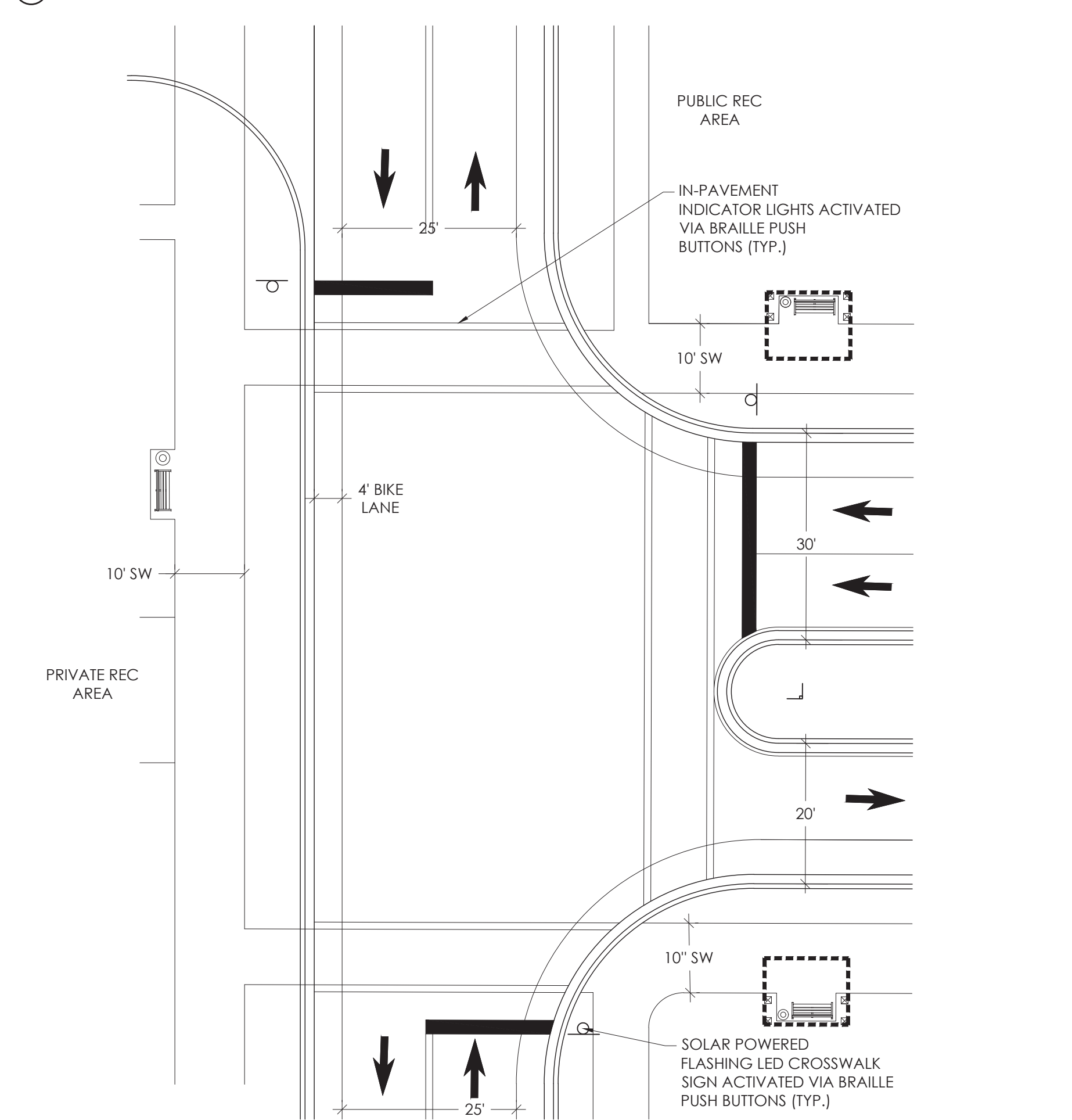

**E MAIN ENTRANCE STREET SECTION - DECO DRIVE (POD A & B)**

NOTE: SPECIMEN PALMS ARE BEING REQUESTED TO BE UTILIZED AS STREET TREES (FLORIDA ROYAL PALMS / DATE PALMS)

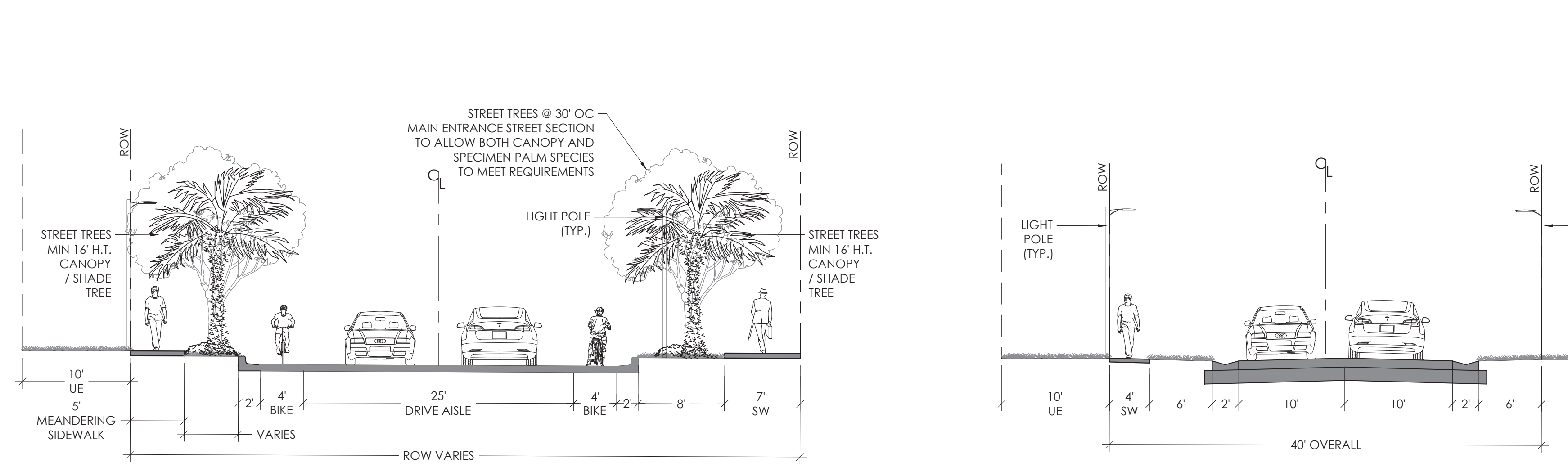

**F SOUTH LAPIS LANE STREET SECTION (POD C-2)**

NOTE: SPECIMEN PALMS ARE BEING REQUESTED TO BE UTILIZED AS STREET TREES (FLORIDA ROYAL PALMS / DATE PALMS)

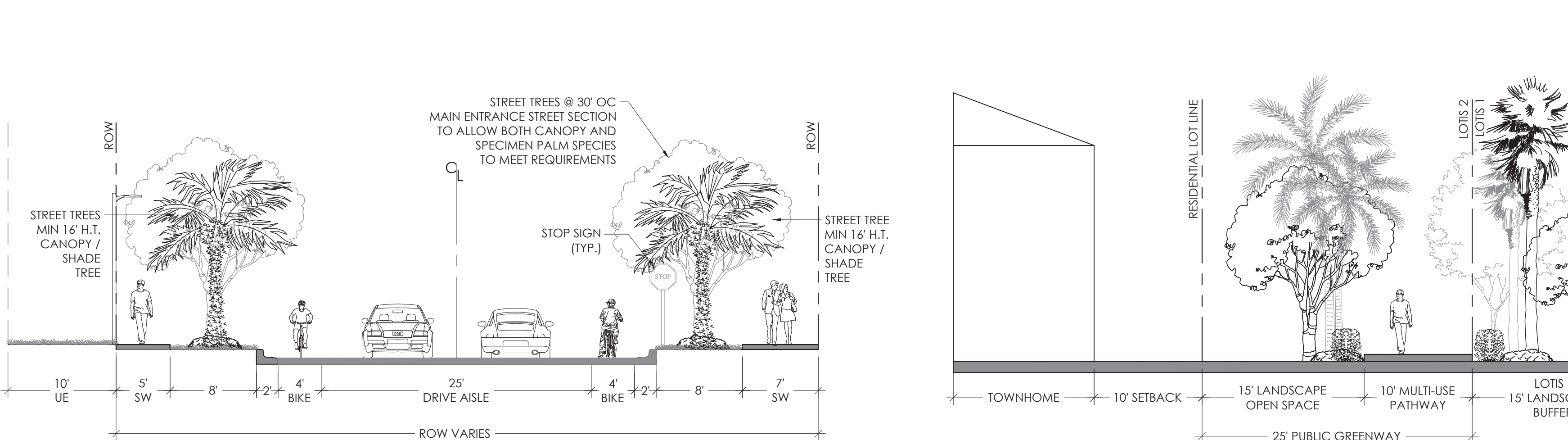

**G NORTH LAPIS LANE STREET SECTION (POD C-2)**

NOTE: SPECIMEN PALMS ARE BEING REQUESTED TO BE UTILIZED AS STREET TREES (FLORIDA ROYAL PALMS / DATE PALMS)

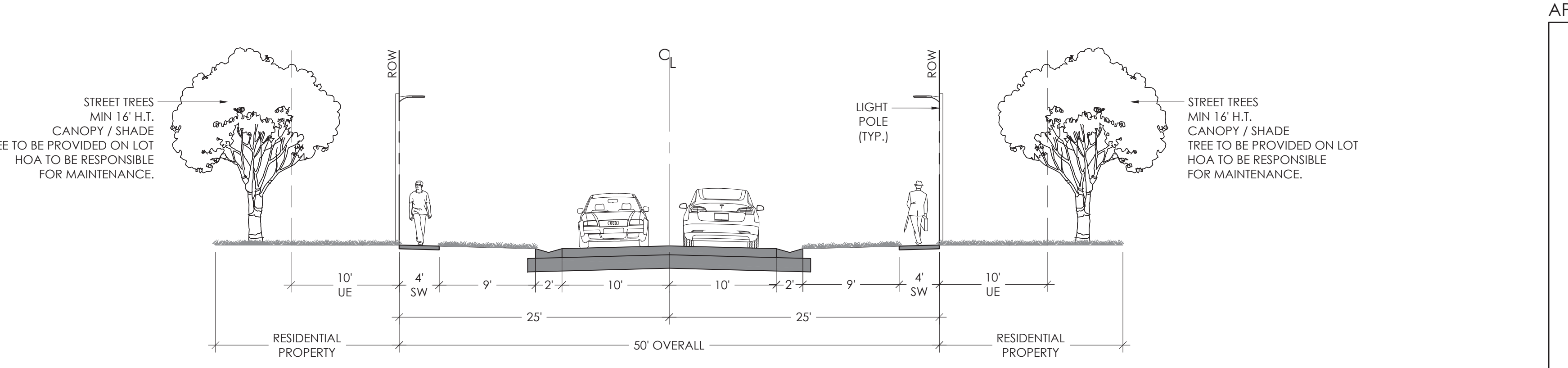

**H 50' ROAD TRACT STREET SECTION - RALEIGH WAY / MONDRIAN STREET / MIRADOR STREET/ CARDOZO COURT (POD C-1)**

NOTE: SPECIMEN PALMS ARE BEING REQUESTED TO BE UTILIZED AS STREET TREES (FLORIDA ROYAL PALMS / DATE PALMS)



**I 40' ROAD TRACT TOWNHOME STREET SECTION - RONEY STREET / CARLON STREET / NATIONAL STREET / RIVO ALTO WAY (POD C-1)**

NOTE: NO STREET TREES WILL BE REQUIRED ALONG THIS 40' ROW SECTION. REQUIRED STREET TREES SHALL BE OFFSET BY PAYMENT TO THE VILLAGE OF WELLINGTON TREE FUND.

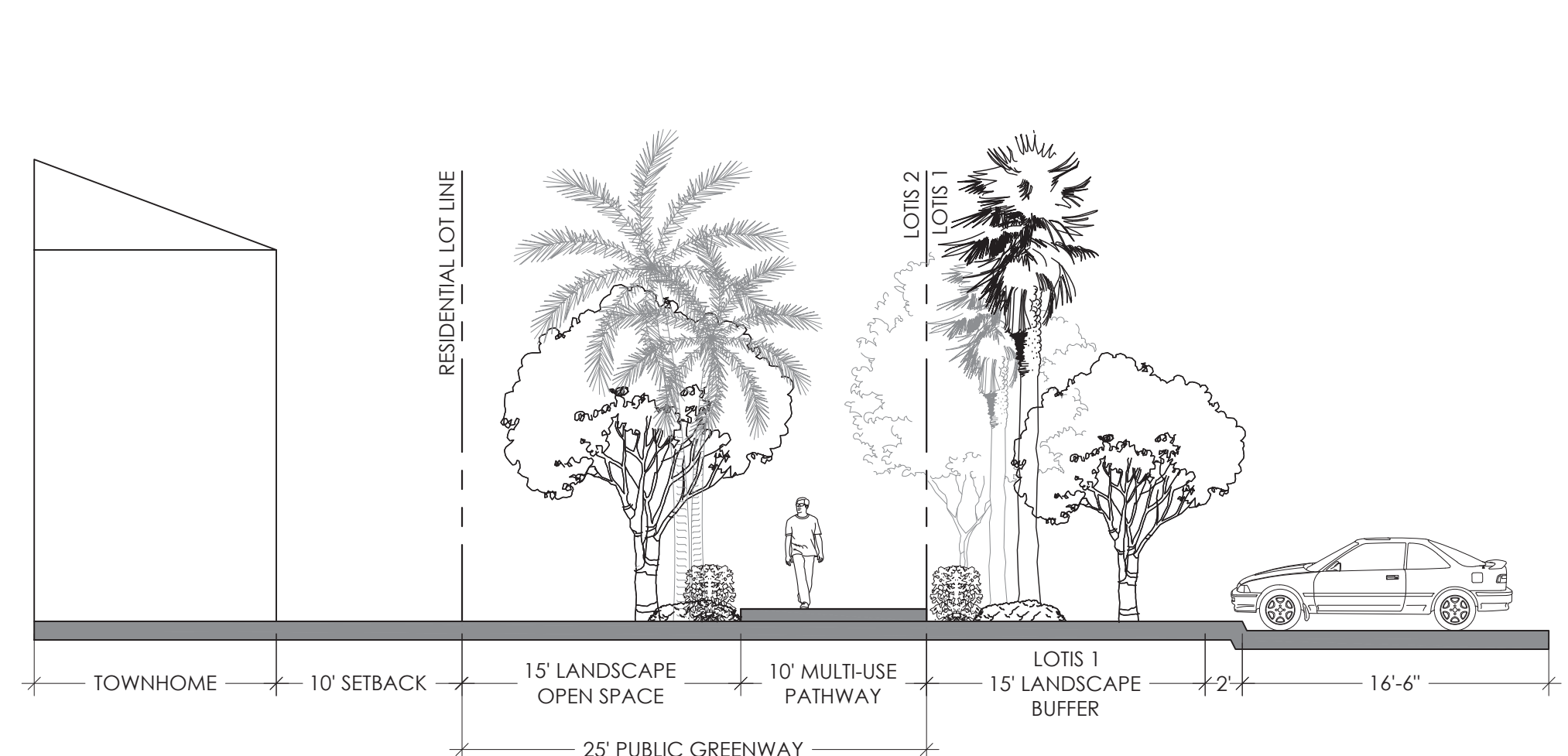

**J LOTIS 1 & 2 PUBLIC GREENWAY SECTION (POD C-1 & E-1)**

NOTE: SPECIMEN PALMS ARE BEING REQUESTED TO BE UTILIZED AS STREET TREES (FLORIDA ROYAL PALMS / DATE PALMS)

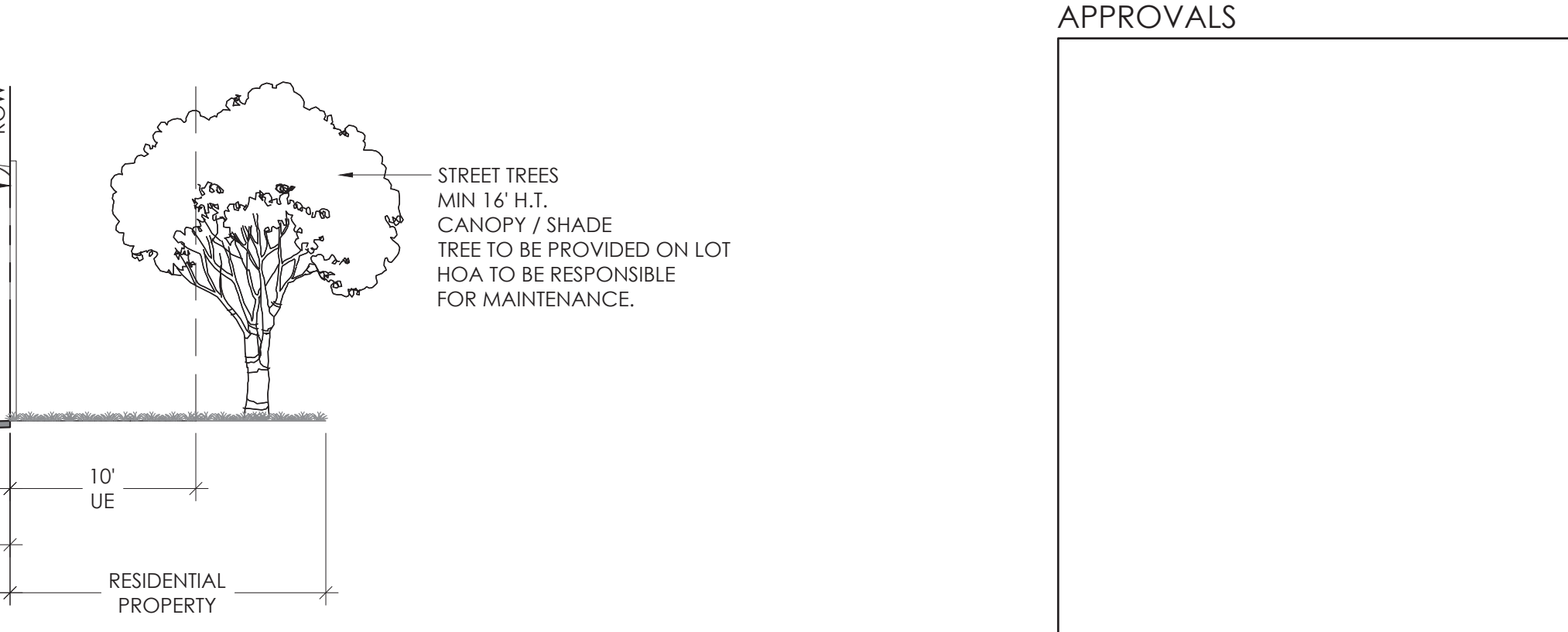

APPROVALS

**LOTIS WELLINGTON II**  
Wellington, Florida

Drawn By: TAC  
Drawing #: 1076  
Date: 05/04/2023

Master  
Regulating Plan

SHEET # MRP.1

**Exhibit B**  
Master Plan including Phasing,  
Regulating Plan and Circulation Plan  
Sheet 1 of 3)

SITE DATA	
PETITION NAME	LOTIS WELLINGTON 2
PETITION NUMBER	2023-0001-SP
LAND USE DESIGNATION	MIXED USE
ZONING DISTRICT	MUPD
OVERLAY(S) / NEIGHBORHOOD PLAN(S)	N/A
PROPERTY CONTROL NUMBER(S)	73-42-43-27-05-018-0072 73-42-43-27-05-018-0071 73-42-43-27-05-018-0040
COMMERCIAL FAR	0.01
RESIDENTIAL DENSITY	3.29 DU/AC
EXISTING USE(S)	VACANT
PROPOSED USE(S)	MIXED USE
GROSS SITE AREA	52.259 AC

DEVELOPMENT TEAM	
<b>DEVELOPER</b>	
LOTIS WELLINGTON 2, LLC. 2300 GLADES RD, SUITE 202E BOCA RATON, FL 33431 561.866.6684	
<b>PLANNER &amp; LANDSCAPE ARCHITECT</b>	
INSITE STUDIO, INC. 3601 PGA BLVD SUITE 220 PALM BEACH GARDENS, FL 33410 561.249.0940	
<b>CIVIL ENGINEER</b>	
SCHNARS ENGINEERING CORP. 947 CLINT MOORE ROAD BOCA RATON, FL 33487 561.241.6455	
<b>TRAFFIC ENGINEER</b>	
JFO GROUP, INC. 6671 W INDIANTOWN RD, SUITE 50-324 JUPITER, FL 33458 561.462.5344	
<b>ENVIRONMENTAL</b>	
ECOTONE SERVICES 13945 89TH STREET FELLSMERE, FL 32948 772.459.3339	
<b>SURVEY</b>	
DENNIS J LEAVY & ASSOCIATES 440 BUSINESS PARK WAY, SUITE B ROYAL PALM BEACH, FL 33411 561.753.0650	



Consultants:

Revisions:

05/16/2023	- Resubmittal
06/28/2023	- Resubmittal
08/02/2023	- Resubmittal
08/25/2023	- Resubmittal
09/21/2023	- Resubmittal

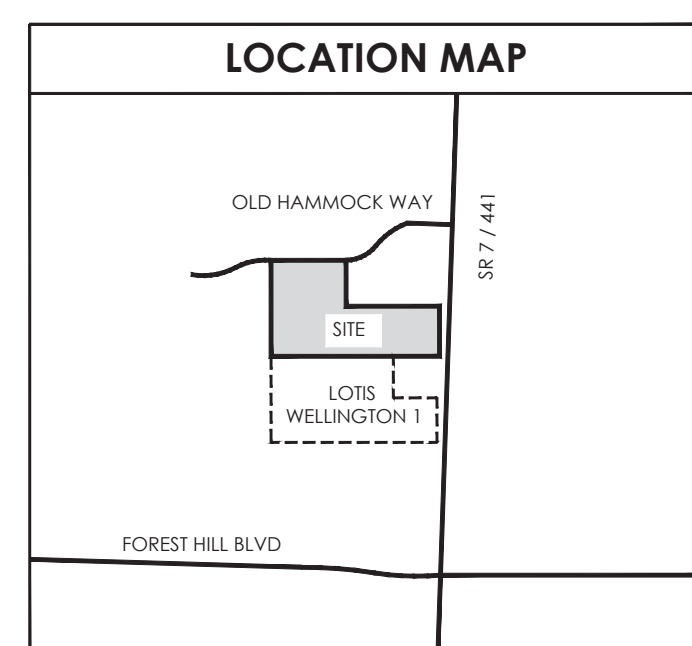
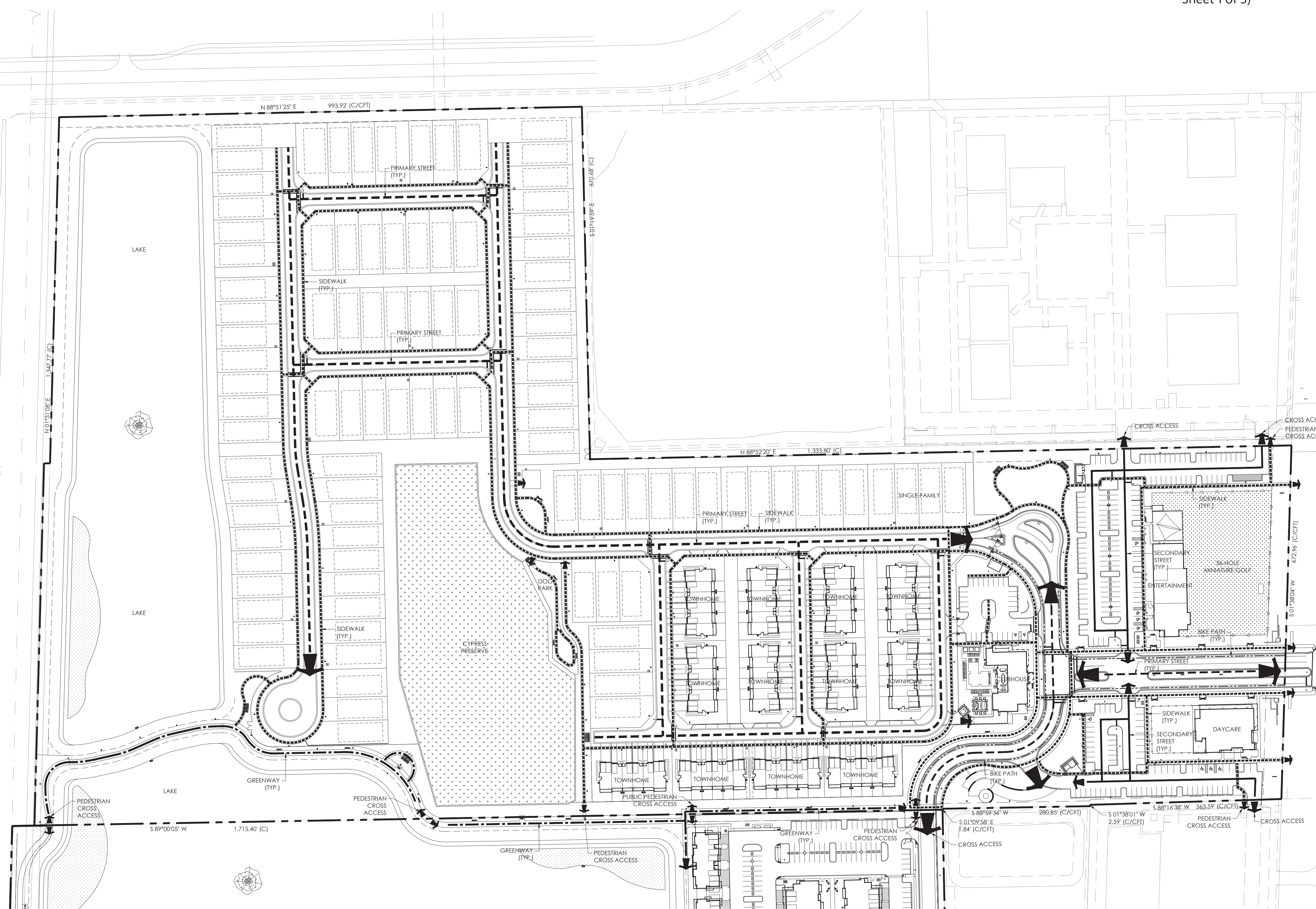

**APPROVALS**

**LEGEND**

- PRIMARY STREET - - - - -
- SECONDARY STREET - - - - -
- SIDEWALK - ·······
- GREENWAY - - - - -
- BIKE PATH - ·······

0 50' 100' 200'  
NORTH  
SCALE: 1" = 100'-0"

Drawn By: TAC  
Drawing #: 1076  
Date: 04/28/2022

Circulation Plan  
SHEET # CP.1

**LOTIS WELLINGTON II**  
Wellington, Florida